

CUTTER

Q1

The ideal cutter for those hard to reach places. With its swivelling head it is able to reach the places where other tools can not. Where your fist can go, the Q1 will go with you. With an amazing performance it is able to cut much more than just a pedal. It is even able to spread! We have users convincing fellow rescuers that the Q1 can beat dedicated cutters and use it on everything they see! For whatever reason you purchase it, we can guarantee you will want it take it for a spin.

Features:

- UltimatePressure

Facts:

- Lightest, most powerful, versatile cutter in its class
- Lightest in its class
- Most powerful confined space combi-cutter
- Highest safety factors on critical parts

**PRESSURE™
ULTIMATE**

Q1 Confined space cutter: the tool to use in hard to reach places

Narrow body: so where your fist can go the Q1 will go with you.

Separated control: for secure control over the tool, or able to be operated by a wingman

Quick connectors: easy and fast to connect. Automatic locking and flat-face design prevent sand and dirt from getting in the couplers. A rescuers' favorite

180° swiveling head: you will be able to position the blades correctly. Confined space is never straightforward...

Advanced blade design: gives you control over the cutting action

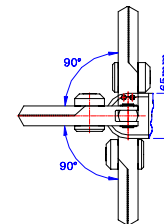

Technical specifications Q1

Model	Q1 Confined space cutter
Nominal pressure	350 Bar / UltimatePressure™
Dimensions (LxWxH)	325 x 218 x 65 mm
Operational weight	6.8 kg
Max. cutting opening	60 mm
Reach	76 mm
Max. cutting force	165 kN / 16.8 ton / 18.5 US tons
Max.spreading opening	80 mm
Max.spreading force	40.6 kN / 4.1 ton / 4.6 US tons
EN13204	AC60/B-7
NFPA 1936	Compliant

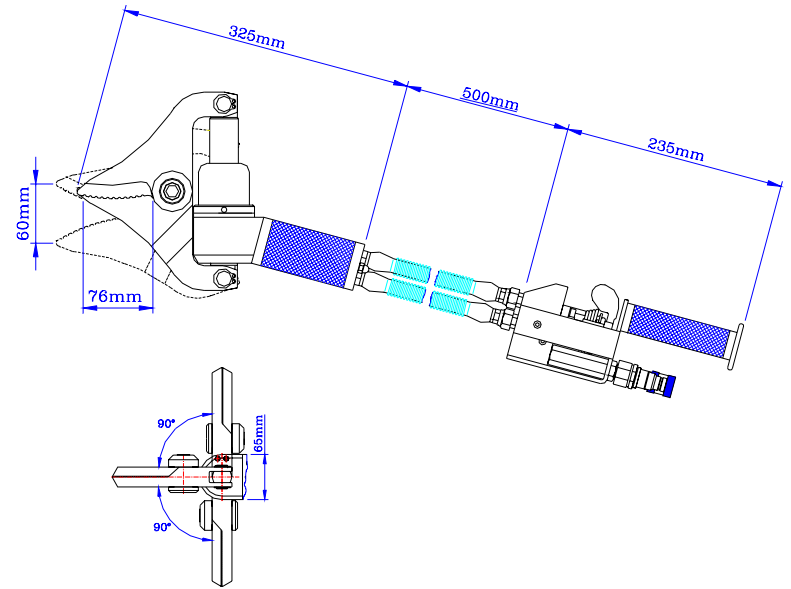

For questions or additional information please e-mail to info@resqtec.com

RESQTEC®

RESQTEC® is a registered trademark

© RESQTEC® 2005
Technical modifications reserved

RESQTEC Zumro b.v.
Meer en Duin 82
2163 HC, Lisse
the Netherlands

T: +31 (0)252 419002
F: +31 (0)252 411794
E: info@resqtec.com
I: www.resqtec.com

RESQTEC, Inc.
3333 Foerster Road
St. Louis, MO 63044
USA

T: (314) 439 2890
F: (314) 439 2895

DS008K00